

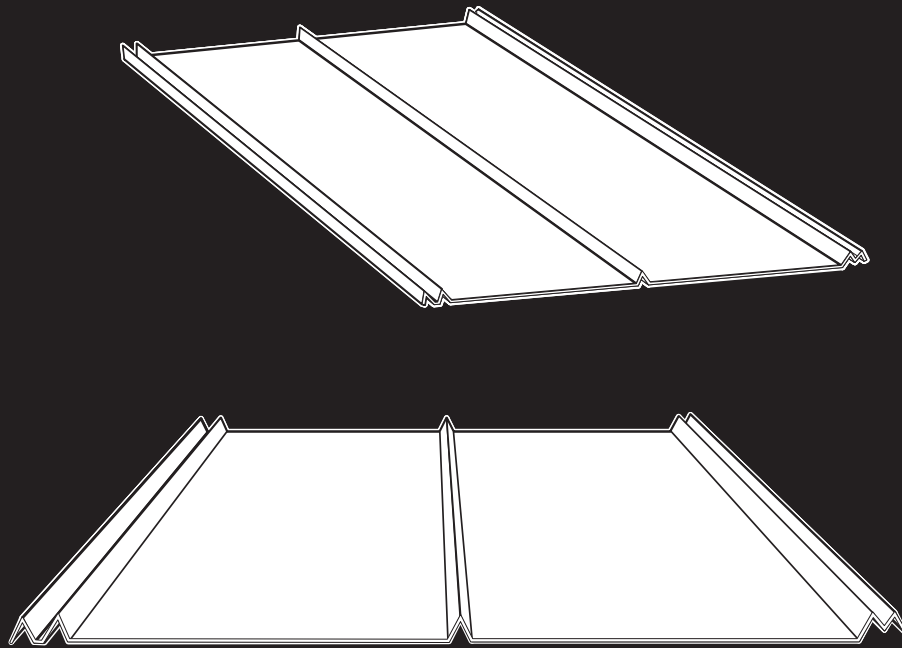

5V Crimp

Design/Installation Information





5V CRIMP PRODUCT INFORMATION

TABLE OF CONTENTS

- A. Architect/Engineer InformationV-2
- B. General DescriptionV-3
- C. UL 90 Construction NumbersV-4
- D. Section PropertiesV-5
- E. Product ChecklistV-6
- F. Fastener PatternsV-7
- G. Typical Details
 - 1. Ridge V-8
 - 2. Alternate Ridge/Hip V-9
 - 3. Endlap V-10
 - 3. Valley V-11
 - 4. Hip V-12
 - 5. Rake V-13
 - 6. Eave V-14
 - 7. Gutter V-15
 - 9. Slope Change V-16

©Copyright American Building Components, 2006
All Rights Reserved.
04-06 – 10M

For the most current information on our products and erection procedures, please check the ABC web site at www.abcmetalroofing.com

Descriptions and specifications contained herein were in effect at the time this publication was approved for printing. In a continuing effort to refine and improve products, ABC reserves the right to discontinue products at any time or change specifications and/or designs without incurring obligation. **To insure you have the latest information available, please inquire or visit our Web Site at www.abcmetalroofing.com.** Application details are for illustration purposes only and may not be appropriate for all environmental conditions, building designs, or panel profiles. Projects should be engineered to conform to applicable building codes, regulations, and accepted industry practices. Insulation is not shown in these details for clarity. **If there is a conflict between this manual and the erection drawings, the erection drawings will take precedence.**



PRODUCT INFORMATION

5V CRIMP

ARCHITECT/ENGINEER INFORMATION

1. Minimum recommended slope is 3:12. For slopes less than 3:12, call ABC.
2. Use a properly aligned and uniform substructure to avoid panel distortion. Typical substructure - $\frac{5}{8}$ " plywood; alternate substructure metal or wood stringers. Spacing of stringers to be determined by load tables. For illustration purposes, details are shown over plywood.
3. 5V Crimp panels are water shedding panels and therefore must be installed on a minimum 3:12 roof slope. The panels must be installed over a completely waterproofed substructure. If the waterproof membrane is mechanically attached with metal fasteners of any type, fasteners should be covered to protect the back side of the roof panels. Any mechanical attachment device that does not lay flat on the deck will telegraph through the panels.
4. Panels are subject to surface distortion due to improperly applied fasteners. Overdriven fasteners will cause stress and induce oil canning across the panel at or near the point of attachment. Oil canning is not a cause for rejection.
5. For proper fastener application, see Product Checklist.
6. For continuous panels over 25', please inquire. Panels may be endlapped.
7. All panel ends must be sealed at eave and valley conditions. Refer to Pages V-11, V-14 and V-15 for end sealant details.
8. Fastener spacings across the width of the panel are shown on Page V-7. For fastener spacings along the length of the panel, use the wind load table on Page V-5 in conjunction with the governing code.

CAUTION

Most of the 5V Crimp load tables indicate panels can obtain a 20# live load on 2'-6" centers when installed over stringers. Please keep in mind these are uniform live loads and will not support a 200 pound man standing on one square foot. From an erectability and industry standard point of view, it is recommended that you should not span the panels more than 2'-6".



5V CRIMP PRODUCT INFORMATION

GENERAL DESCRIPTION

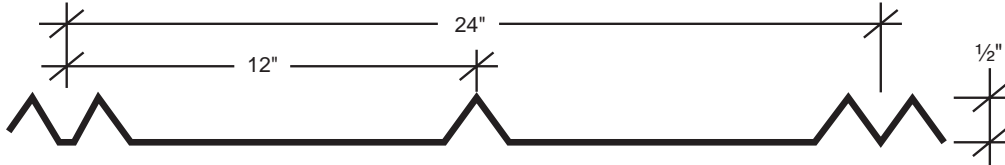

Coverage Width - 24"

Minimum Slope - 3:12

Panel Attachment - Wood screws

Panel Substrate - Galvanized or Galvalume Plus®

Gauges - 29 or 26

Finishes - Smooth or embossed

Coating - Signature® 200 (Siliconized Polyester)

PRODUCT SELECTION CHART

Product	Galvanized	Galvalume Plus ®	Signature® 200
5V Crimp	29	26	26
24" Wide	●	●	●

- - Available in any quantity.
- - Minimum quantity may be required.

PRODUCT INFORMATION

5V CRIMP

UL 90 Requirements 5V Crimp Construction # 453

1. Metal Panels (26 gauge) – 24" wide, continuous over two or more spans.
2. Fastener spacing along the length of the panel is 3 feet on center.
3. Fasteners – No.14-10 x 1½" Type A, Hex Head with separate 5/8 in. O.D. steel washer and a bonded neoprene washer. Fastener spacing is as follows: a line of fasteners is to be installed adjacent to the double "V" in the middle of the panel for a total of four fasteners across the width of the panel. Fastener spacing along the length of the panel is 3 feet on center.

FIRE RESISTANCE RATING

The panel qualifies for a Class A fire rating when installed over a non-combustible substrate in compliance with Underwriters Laboratories Standard UL-263. Panels installed over combustible substrate will qualify for a Class C Fire Rating only.

IMPACT RESISTANCE

The 5V panels carry a Class 4 rating under UL-2218 "Test Standard For Impact Resistance".

For UL 90 Rated Roofs, the above requirements must be followed. See UL Roofing Materials and Systems Directory for additional requirements. If you have any questions, call ABC before proceeding.



5V CRIMP PRODUCT INFORMATION

5V CRIMP 24" Coverage

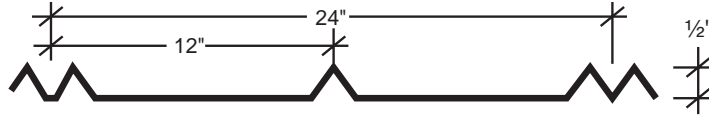

PANEL GAUGE	Fy (KSI)	WEIGHT (PSF)	NEGATIVE BENDING			POSITIVE BENDING		
			Ixe (IN.4/FT.)	Sxe (IN.3/FT.)	Maxo (KIP-IN.)	Ixe (IN.4/FT.)	Sxe (IN.3/FT.)	Maxo (KIP-IN.)
29	60*	0.75	0.0014	0.0074	0.2662	0.0028	0.0061	0.2204
26	60*	0.95	0.0018	0.0112	0.4018	0.0032	0.0079	0.2826

*Fy is 80 ksi reduced to 60 ksi in accordance with the 2001 edition of the *North American Specification For Design of Cold-Formed Steel Structural Members* - A2.3.2.

NOTES:

- All calculations for the properties of 5V Crimp panels are calculated in accordance with the 2001 edition of the *North American Specification For Design of Cold-Formed Steel Structural Members*.
- Ixe is for deflection determination.
- Sxe is for Bending.
- Maxo is allowable bending moment.
- All values are for the one foot of panel width.

29 Gauge (Fy = 60ksi)		ALLOWABLE UNIFORM LOADS IN POUNDS PER SQUARE FOOT						
SPAN TYPE	LOAD TYPE	SPAN IN FEET						
		1.0	1.5	2.0	2.5	3.0	3.5	4.0
SINGLE	Negative Wind Load	177.5	78.9	44.4	28.4	19.7	14.5	11.1
	Live Load/Deflection	146.9	65.3	30.2	15.4	8.9	5.6	3.8
2 SPAN	Negative Wind Load	146.9	65.3	36.7	23.5	16.3	12.0	9.2
	Live Load/Deflection	142.1	64.3	36.4	23.4	16.3	12.0	9.1
3 SPAN	Negative Wind Load	183.7	81.6	45.9	29.4	20.4	15.0	11.5
	Live Load/Deflection	172.5	79.9	45.4	29.1	16.9	10.6	7.1
4 SPAN	Negative Wind Load	171.5	76.2	42.9	27.4	19.1	14.0	10.7
	Live Load/Deflection	164.4	74.8	42.4	27.2	17.9	11.3	7.6

26 Gauge (Fy = 60ksi)		ALLOWABLE UNIFORM LOADS IN POUNDS PER SQUARE FOOT						
SPAN TYPE	LOAD TYPE	SPAN IN FEET						
		1.0	1.5	2.0	2.5	3.0	3.5	4.0
SINGLE	Negative Wind Load	267.9	119.1	67.0	42.9	29.8	21.9	16.7
	Live Load/Deflection	188.4	83.4	35.2	18.0	10.4	6.6	4.4
2 SPAN	Negative Wind Load	188.4	83.7	47.1	30.1	20.9	15.4	11.8
	Live Load/Deflection	182.4	82.5	46.7	30.0	20.9	15.3	10.6
3 SPAN	Negative Wind Load	235.5	104.7	58.9	37.7	26.2	19.2	14.7
	Live Load/Deflection	224.9	102.5	58.2	34.0	19.7	12.4	8.3
4 SPAN	Negative Wind Load	219.9	97.7	55.0	35.2	24.4	18.0	13.7
	Live Load/Deflection	211.0	95.9	54.4	34.9	20.9	13.2	8.8

NOTES:

- Allowable loads are based on uniform span lengths and Fy = 60ksi.
- LIVE LOAD is limited by bending, shear, combined shear & bending, or web crippling.
- NEGATIVE WIND LOAD does not contain a 33.333% increase and does not consider fastener pullout or pullover.
- Above loads consider a maximum deflection ratio of L/180.
- The weight of the panel has not been deducted from the allowable loads.
- The use of any accessories other than those provided by the manufacturer may damage panels, void all warranties and will void all engineering data.
- This material is subject to change without notice.
- See www.americanbuildingcomponents.com for most current information.

The Engineering data contained herein is for the expressed use of customers and design professionals. Along with this data, it is recommended that the design professional have a copy of the most current version of the *North American Specification for the Design of Cold-Formed Steel Structural Members* published by the *American Iron and Steel Institute* to facilitate design. This Specification contains the design criteria for cold-formed steel components. Along with the Specification, the designer should reference the most current building code applicable to the project jobsite in order to determine environmental loads. If further information or guidance regarding cold-formed design practices is desired, please contact the manufacturer.

PRODUCT INFORMATION 5V CRIMP

PRODUCT CHECKLIST

Panel

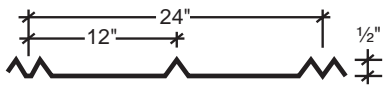

Ridge/Hip

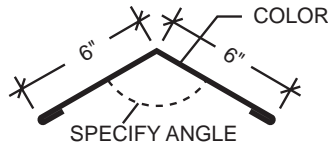

Specify Roof Pitch

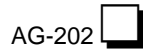

Valley

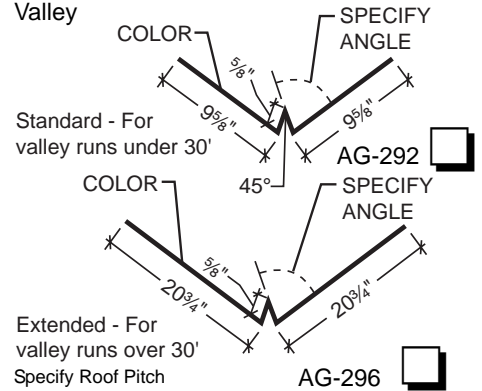

Standard - For valley runs under 30'
Extended - For valley runs over 30'
Specify Roof Pitch

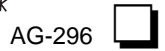

Rake Trim

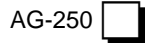
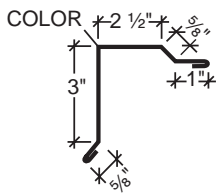

Drip Edge

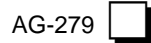
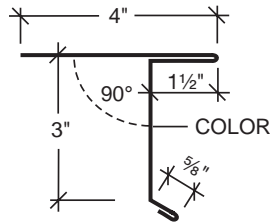

Box Gutter

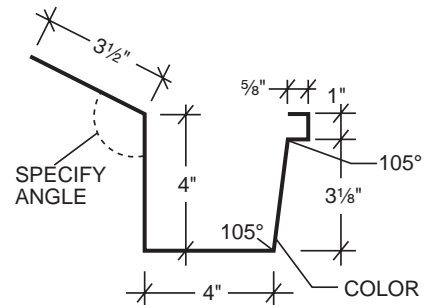

Specify Roof Pitch



Eave Trim

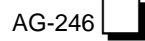
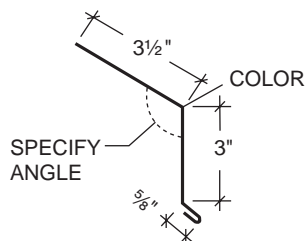

Outside Closure

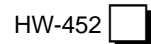

Inside Closure

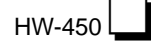

Tri-Bead Tape Sealer

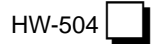

Triple Bead Tape Sealer

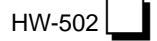

Continuous Cleat

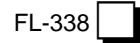
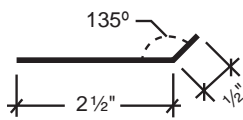

"Z" Closure

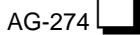
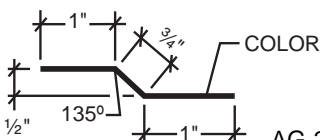

Urethane Tube Sealant

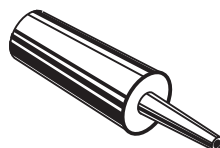

Fastener #9
10 x 1 1/2" Long Life
Woodgrip

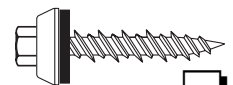

Fastener #13
10 x 1" Pancake
Head



Fastener #4 14 x 7/8"
Long Life Lap Tek

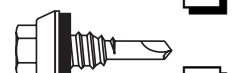

Fastener #14
1/8 x 3/16 Pop Rivet
Stainless Steel





5V CRIMP PRODUCT INFORMATION

FASTENER PATTERNS

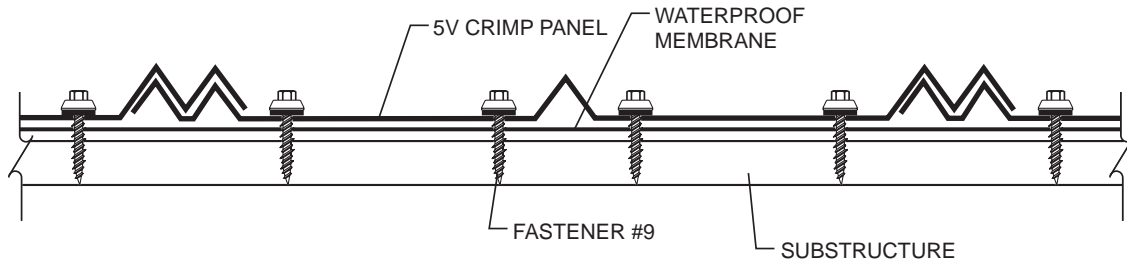

FASTENER PATTERN AT EAVE AND ENDLAP

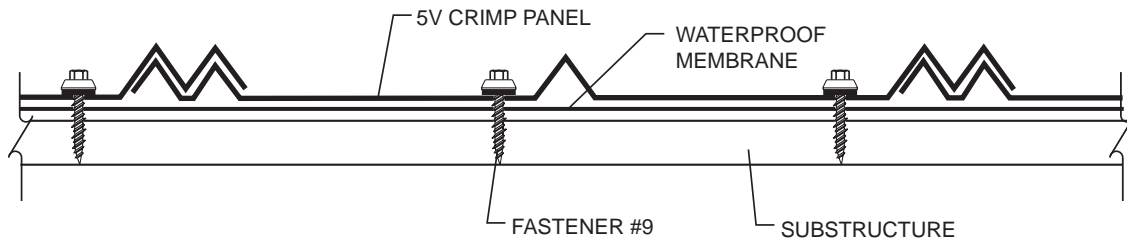

FASTENER PATTERN AT INTERIOR OF PANEL

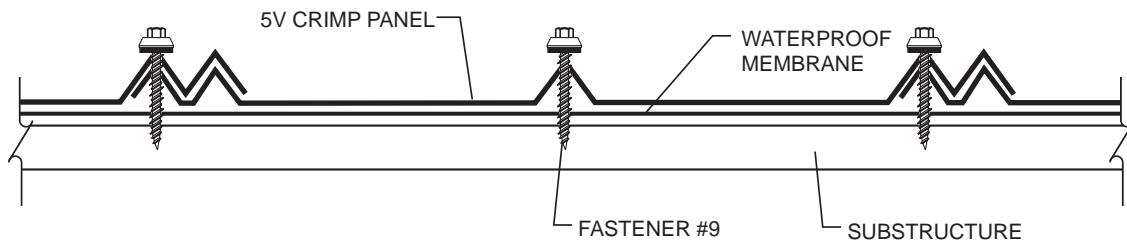

ALTERNATE FASTENER PATTERN



PRODUCT INFORMATION

5V CRIMP

TYPICAL DETAILS RIDGE

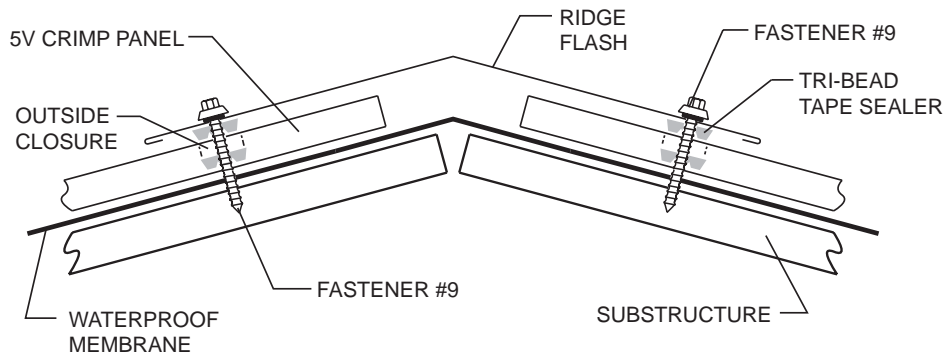

CROSS SECTION OF RIDGE OVER WOOD DECK

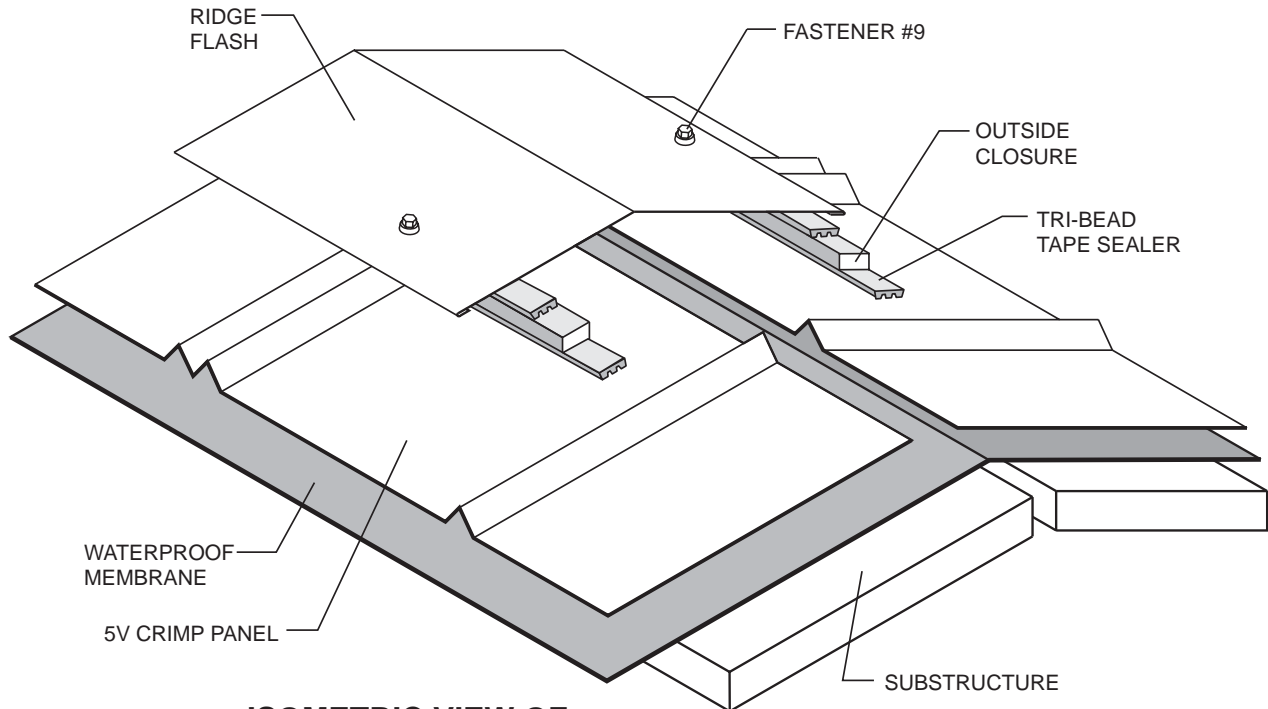

ISOMETRIC VIEW OF RIDGE OVER WOOD DECK

NOTES:

1. Stop panels 2" from center line of ridge.
2. Install first row of fasteners across panel to substrate 1'-0" down from bottom edge of ridge trim and space 1'-0" O.C.
3. Install Tri-Bead tape sealer across width of panels. Top edge of tape sealer is 1 $\frac{3}{4}$ " from top edge of panel. Install outside closures on top of Tri-Bead tape sealer. Install additional run of tape sealer on top of outside closure.
4. Attach ridge flash with Fastener #9 (10 x 1 $\frac{1}{2}$ " Long Life Woodgrip) 1'-0" O.C. Install fasteners at each "V" in the panel to avoid dimpling the ridge flash.

5V CRIMP PRODUCT INFORMATION

TYPICAL DETAILS ALTERNATE RIDGE/HIP

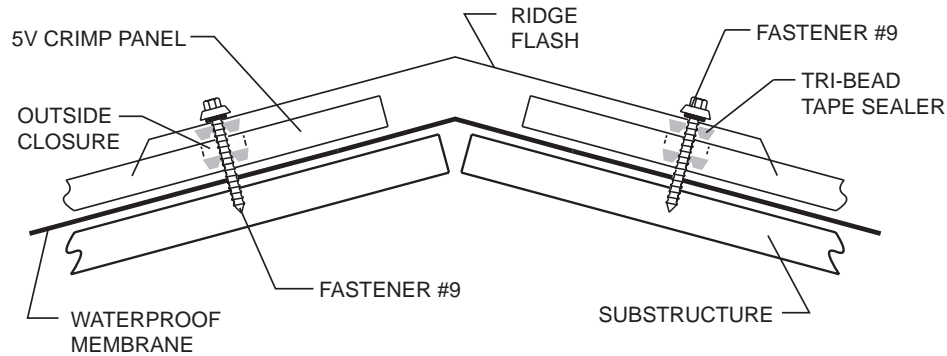

CROSS SECTION OF RIDGE OVER WOOD DECK

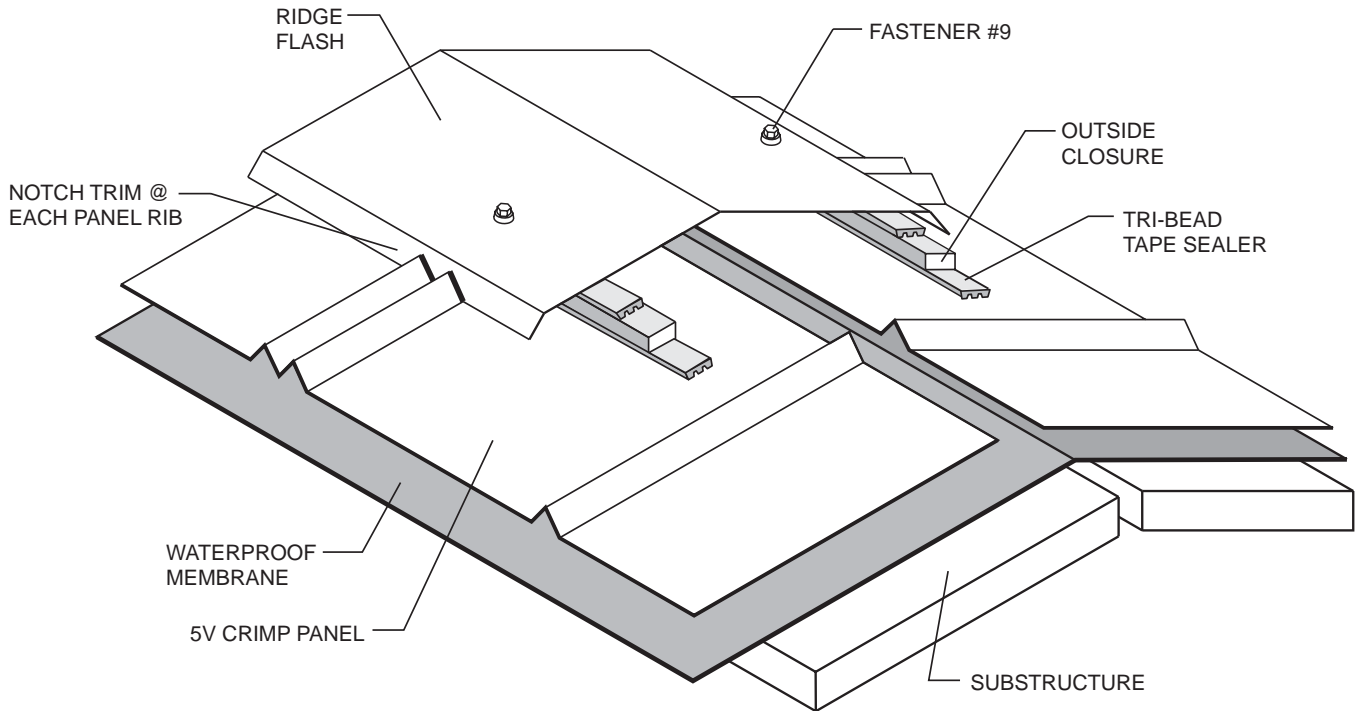

ISOMETRIC VIEW OF RIDGE OVER WOOD DECK

NOTES:

1. Stop panels 2" from center line of ridge.
2. Install first row of fasteners across panel to substrate 1'-0" down from bottom edge of ridge trim and space 1'-0" O.C.
3. Install Tri-Bead tape sealer across width of panels. Top edge of tape sealer is 1¾" from top edge of panel. Install outside closures on top of Tri-Bead tape sealer. Install additional run of tape sealer on top of outside closure.
4. Attach ridge flash with Fastener #9 (10 x 1½" Long Life Woodgrip) 1'-0" O.C. Install fasteners at each "V" in the panel to avoid dimpling the ridge flash.



PRODUCT INFORMATION 5V CRIMP

TYPICAL DETAILS ENDLAP

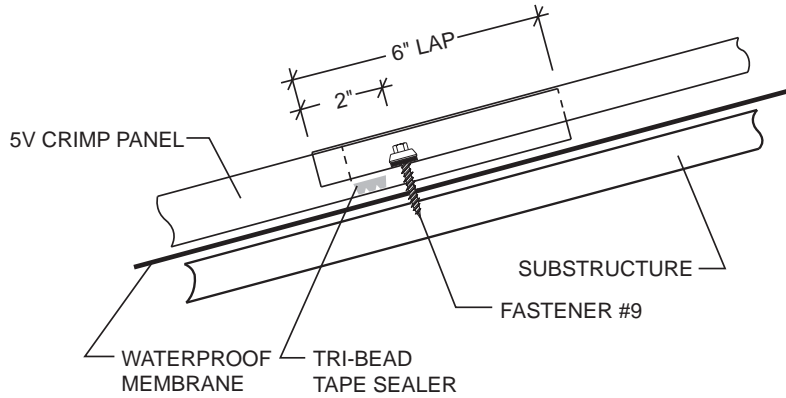

CROSS SECTION OF ENDLAP OVER WOOD DECK

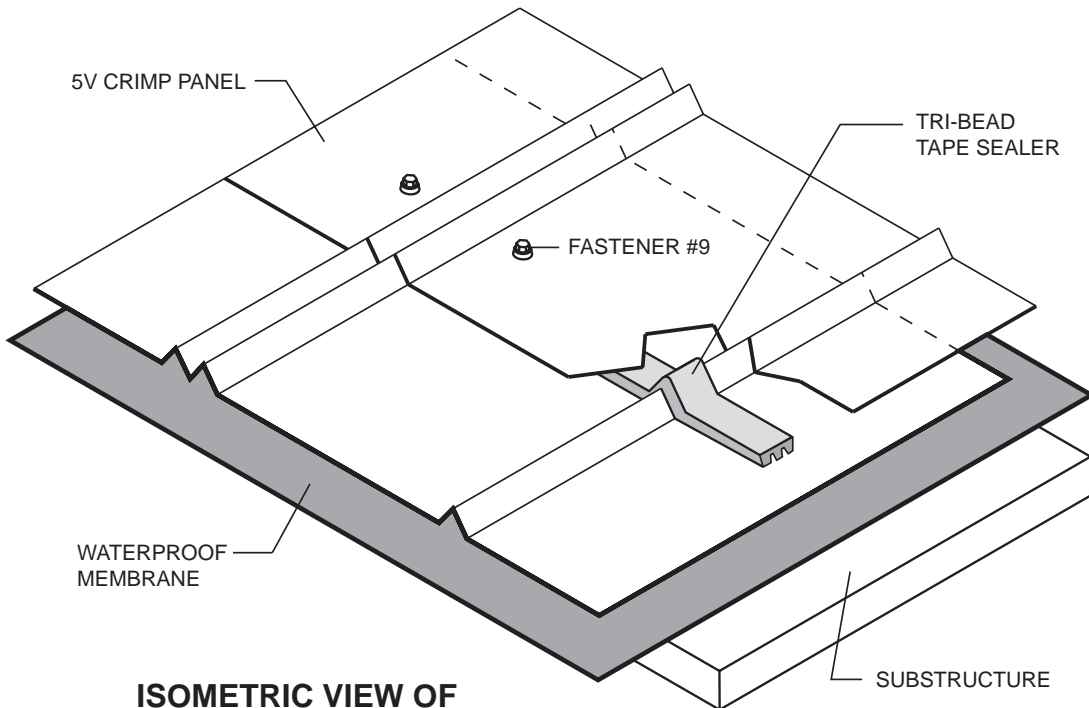

ISOMETRIC VIEW OF ENDLAP OVER WOOD DECK

NOTES:

1. Panel endlap is 6".
2. Install Tri-Bead tape sealer across width of bottom panel before installation of top panel. Top edge of tape sealer is 4³/₄" from upslope end of bottom panel.
3. Fastener pattern at endlap is shown on Page V-7.



5V CRIMP PRODUCT INFORMATION

TYPICAL DETAILS VALLEY

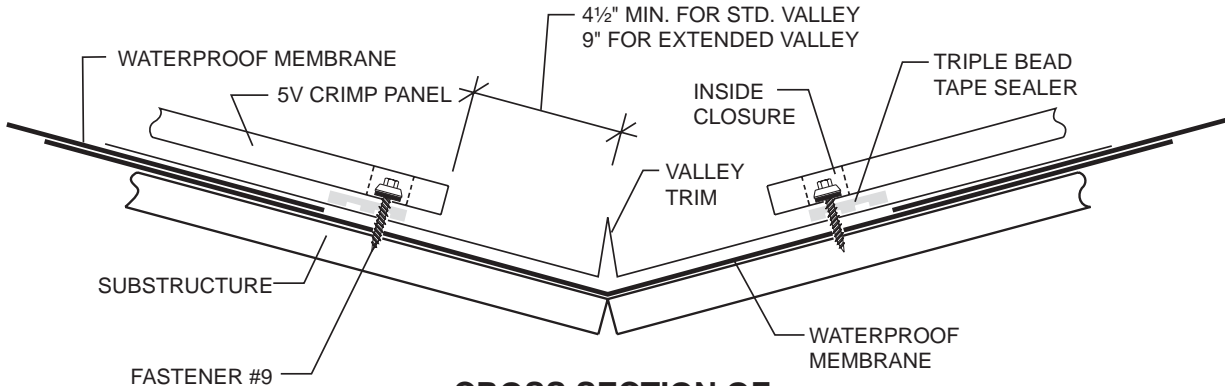

CROSS SECTION OF VALLEY OVER WOOD DECK

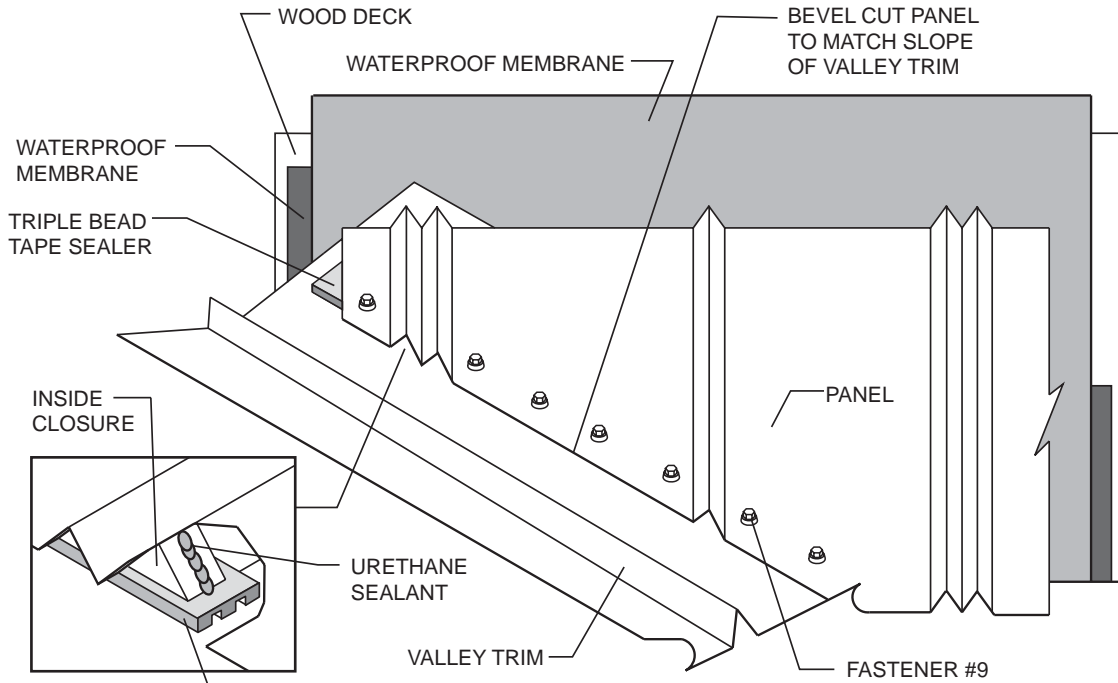

PANEL END DETAIL

ISOMETRIC VIEW OF VALLEY OVER WOOD DECK

NOTES:

1. For valleys 30' or less in length, use standard valley trim. Valleys longer than 30' require extended valley trim.
2. Use waterproof membrane as a waterproof membrane in the valley area.
3. Apply Triple bead tape sealer to valley trim parallel to slope. Bottom edge of tape sealer is 1" from end of panel.
4. Bevel cut panel to match slope of valley trim.
5. Cut "V" from inside closure. Install "V" under panel and on top of Triple bead tape sealer. Install a bed of urethane sealant to top of "V".
6. Fasten panel at valley with Fastener #9 (10 x 1 1/2" Long Life Woodgrip) 4" O.C. maximum.



PRODUCT INFORMATION 5V CRIMP

TYPICAL DETAILS HIP

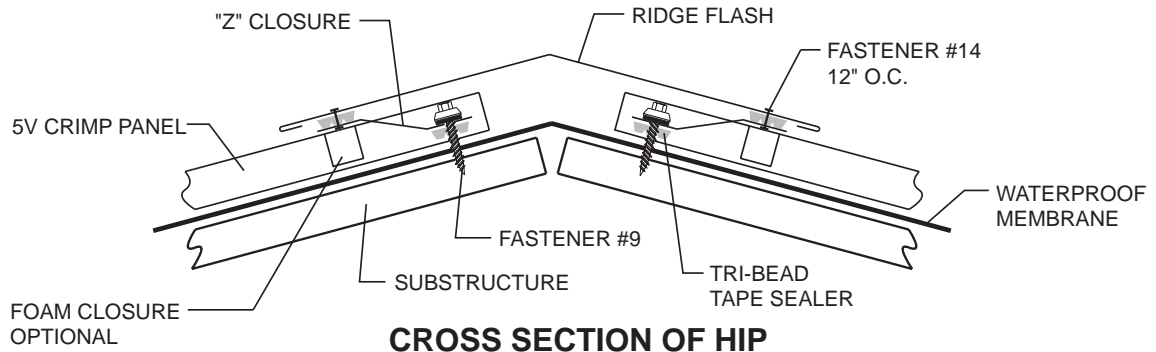

CROSS SECTION OF HIP

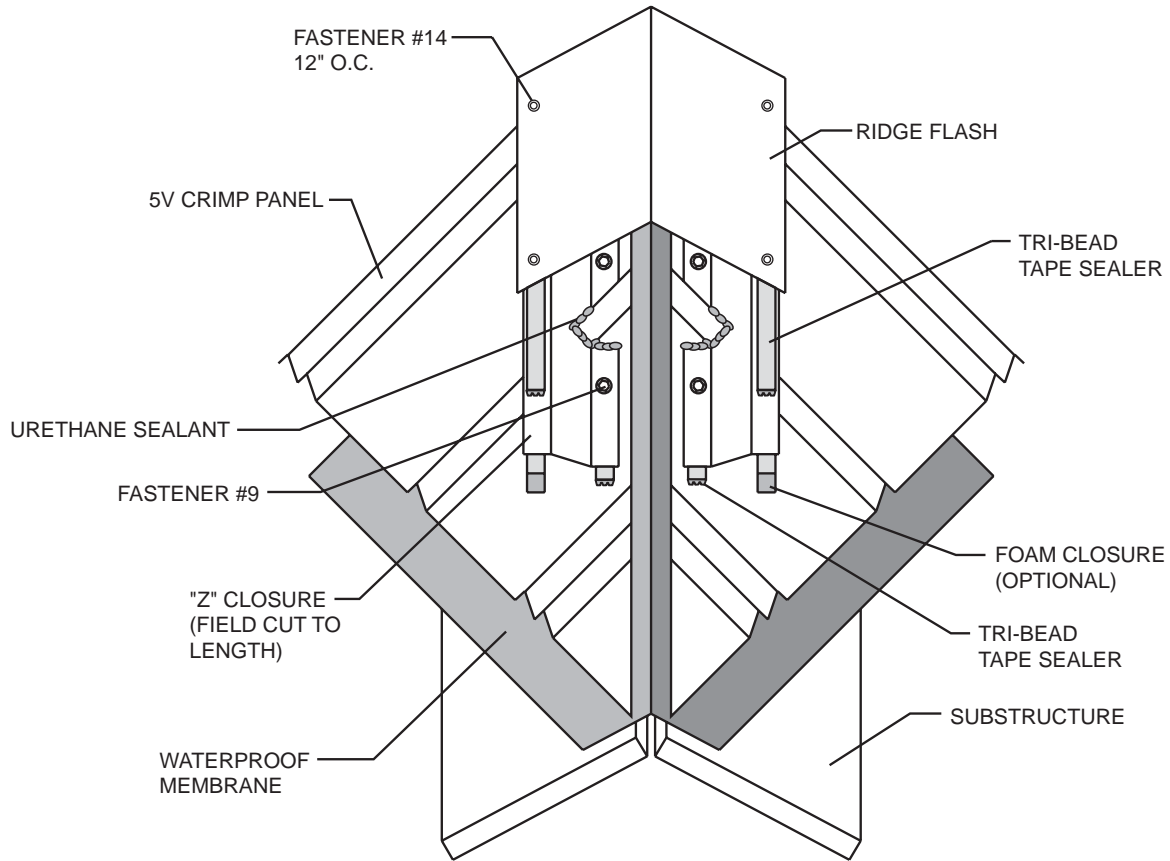

ISOMETRIC VIEW OF HIP

NOTES:

1. Bevel cut panels to match slope of hip and install.
2. Install Tri-Bead tape sealer across panels parallel to slope of hip. Top edge of tape sealer is 1 1/2" from center of hip.
3. Notch bottom flange and web of "Z" closure at each "V" of the panel. Install "Z" closure with Fastener #9 (10 x 1 1/2" Long Life Woodgrip) 1'-0" O.C. Set bottom flange of "Z" closure on top of tape sealer.
4. Install Tri-Bead tape sealer to top flange of "Z" closure and attach hip flash with Fastener #14 (1/8 x 3/16 Pop Rivet) 1'-0" O.C. **Do Not attach to Panel Rib.**

5V CRIMP PRODUCT INFORMATION

TYPICAL DETAILS RAKE

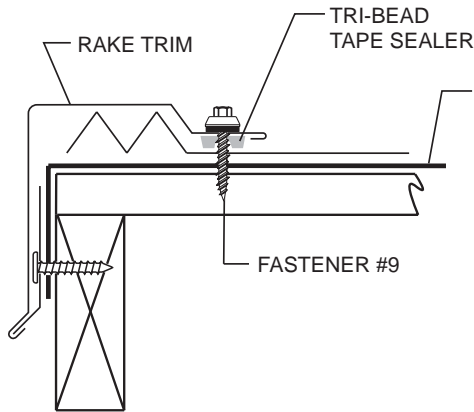

**BEGINNING/FINISHING
RAKE TRIM**

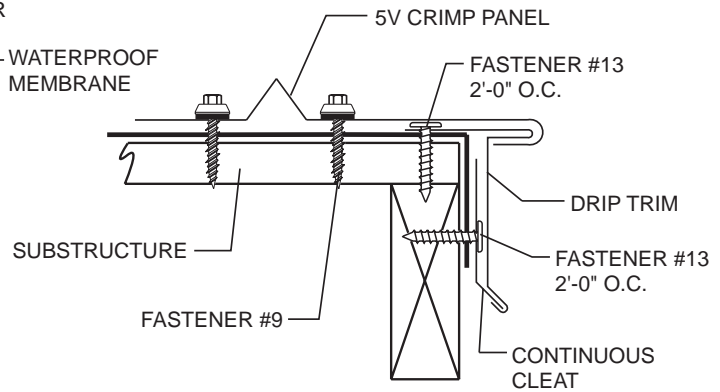

**ALTERNATE
BEGINNING/FINISHING
DRIP TRIM**

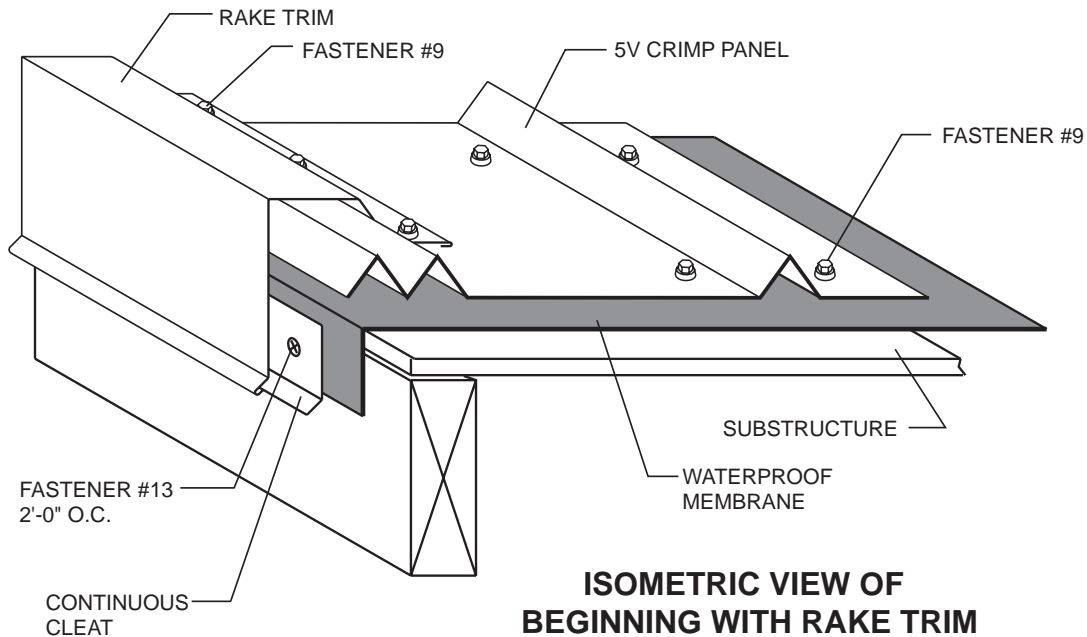

**ISOMETRIC VIEW OF
BEGINNING WITH RAKE TRIM**

NOTES:

Rake Trim

1. Install rake trim to roof panels with Fastener #9 (10 x 1½" Long Life Woodgrip) 1'-0" O.C. Fasteners must go through Tri-Bead tape sealer.
2. When finishing off module, field bend a ½" leg up on panel before installing rake trim.

Alternate Drip Trim

1. Fasten drip trim to roof deck with Fastener #13 (10 x 1" Pancake Head) 2'-0" O.C.
2. Cut panel and bend a 1" open hem along length of panel.
3. Hook panel onto extending leg of drip trim and fasten panel to roof deck in normal manner.

PRODUCT INFORMATION 5V CRIMP

TYPICAL DETAILS EAVE TRIM

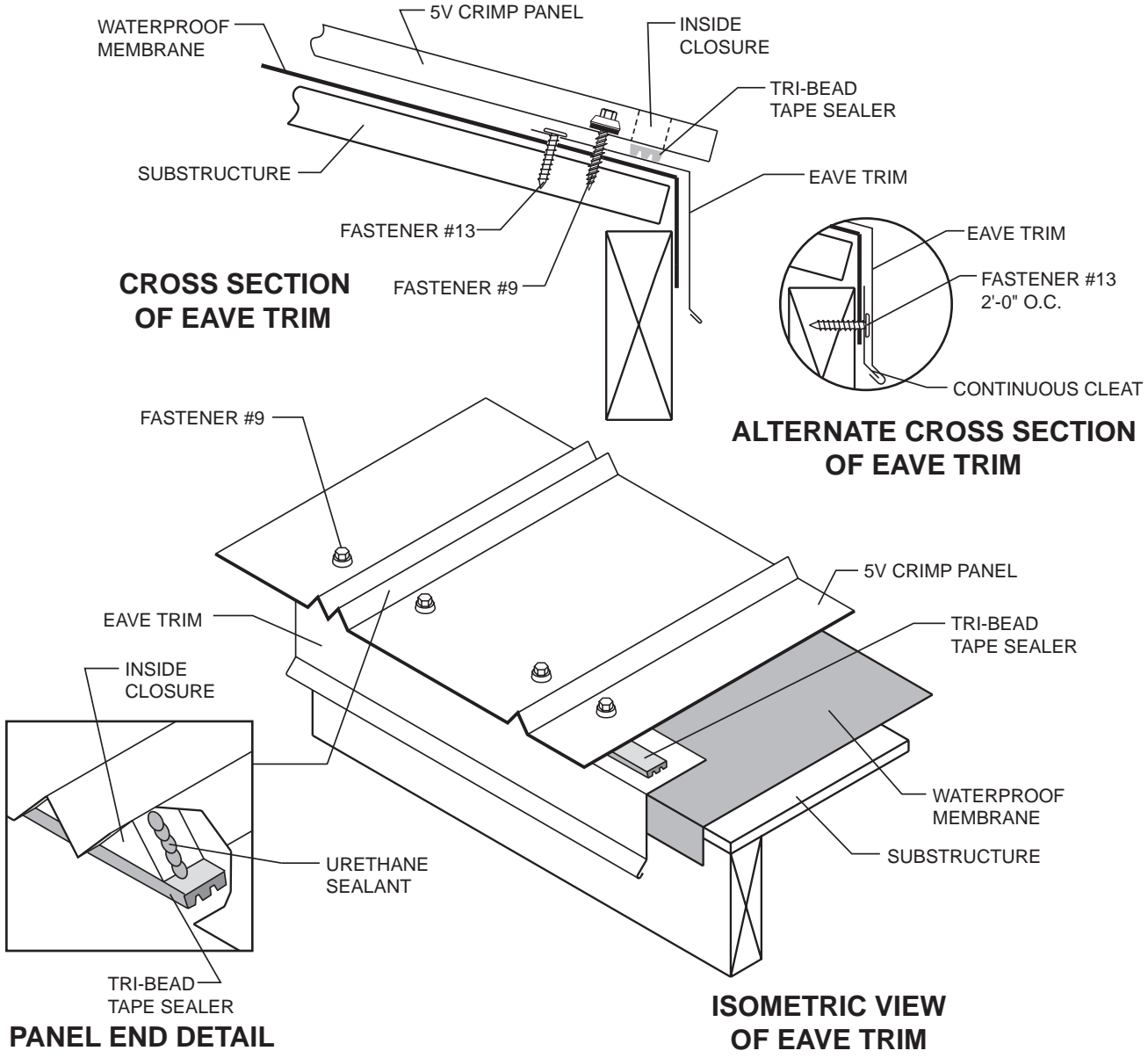

NOTES:

1. Attach eave trim to roof deck with Fastener #13 (10 x 1" Pancake Head) (2 fasteners per 10' section).
2. Install Tri-Bead tape sealer along top leg of eave trim. Install inside closure on top of Tri-Bead tape sealer. Apply a bead of urethane sealant to top of outside closure.
3. Attach panel at eave with Fastener #9 (10 x 1½" Long Life Woodgrip). Fastener pattern is shown on Page V-7.



5V CRIMP PRODUCT INFORMATION

TYPICAL DETAILS GUTTER

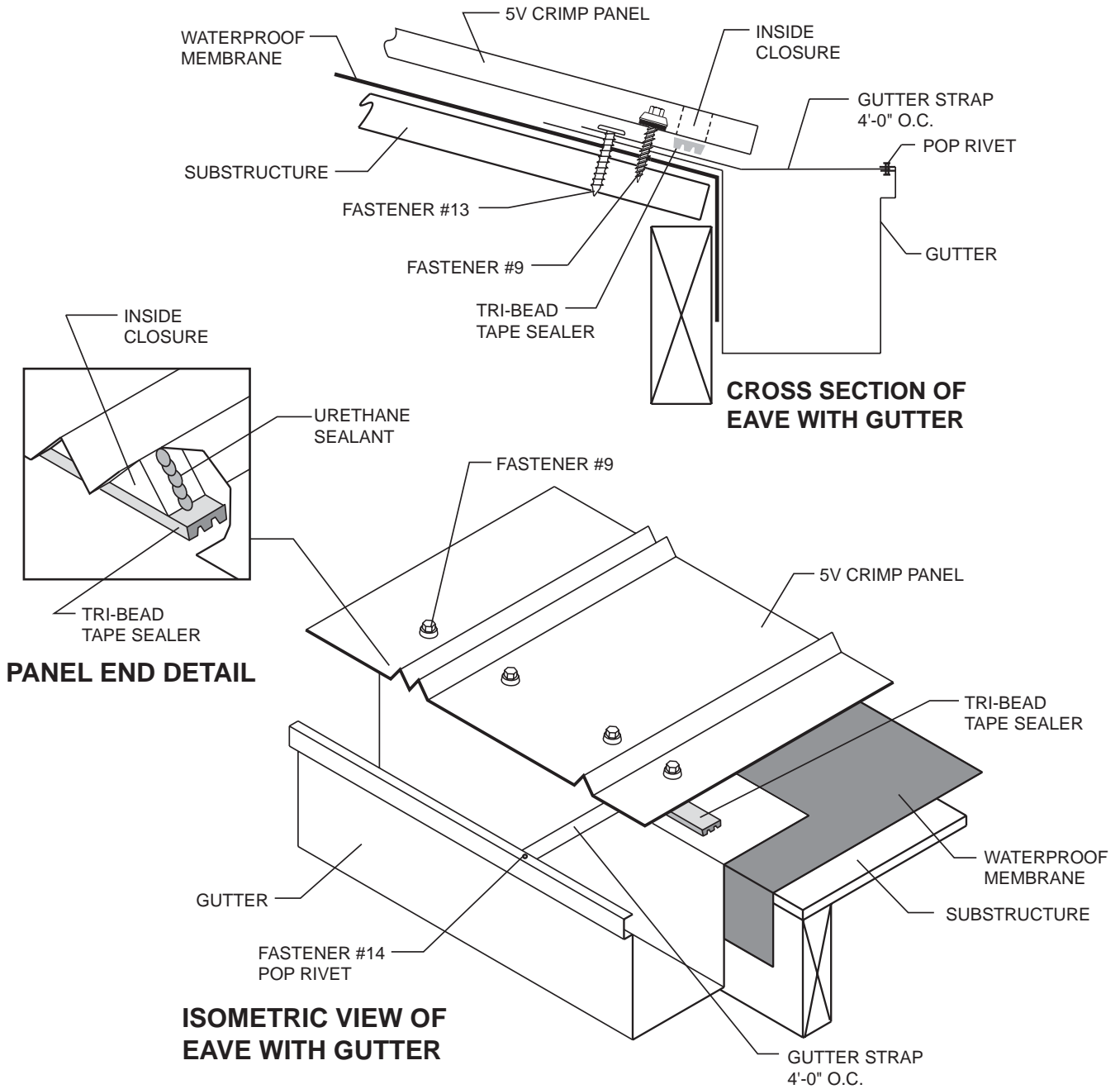

NOTES:

1. Fastener #14 (pop rivet) gutter strap to gutter 4'-0" O.C. and attach gutter to roof deck with two Fastener #13 (10 x 1" Pancake Head) per 10' section.
2. Install Tri-Bead tape sealer along top leg of gutter. Install inside closure on top of Tri-Bead tape sealer. Apply a bead of urethane sealant to top of outside closure.
3. Attach panel at eave with Fastener #9 (10 x 1½" Long Life Woodgrip). Fastener pattern is shown on Page V-7.



PRODUCT INFORMATION 5V CRIMP

TYPICAL DETAILS SLOPE CHANGE

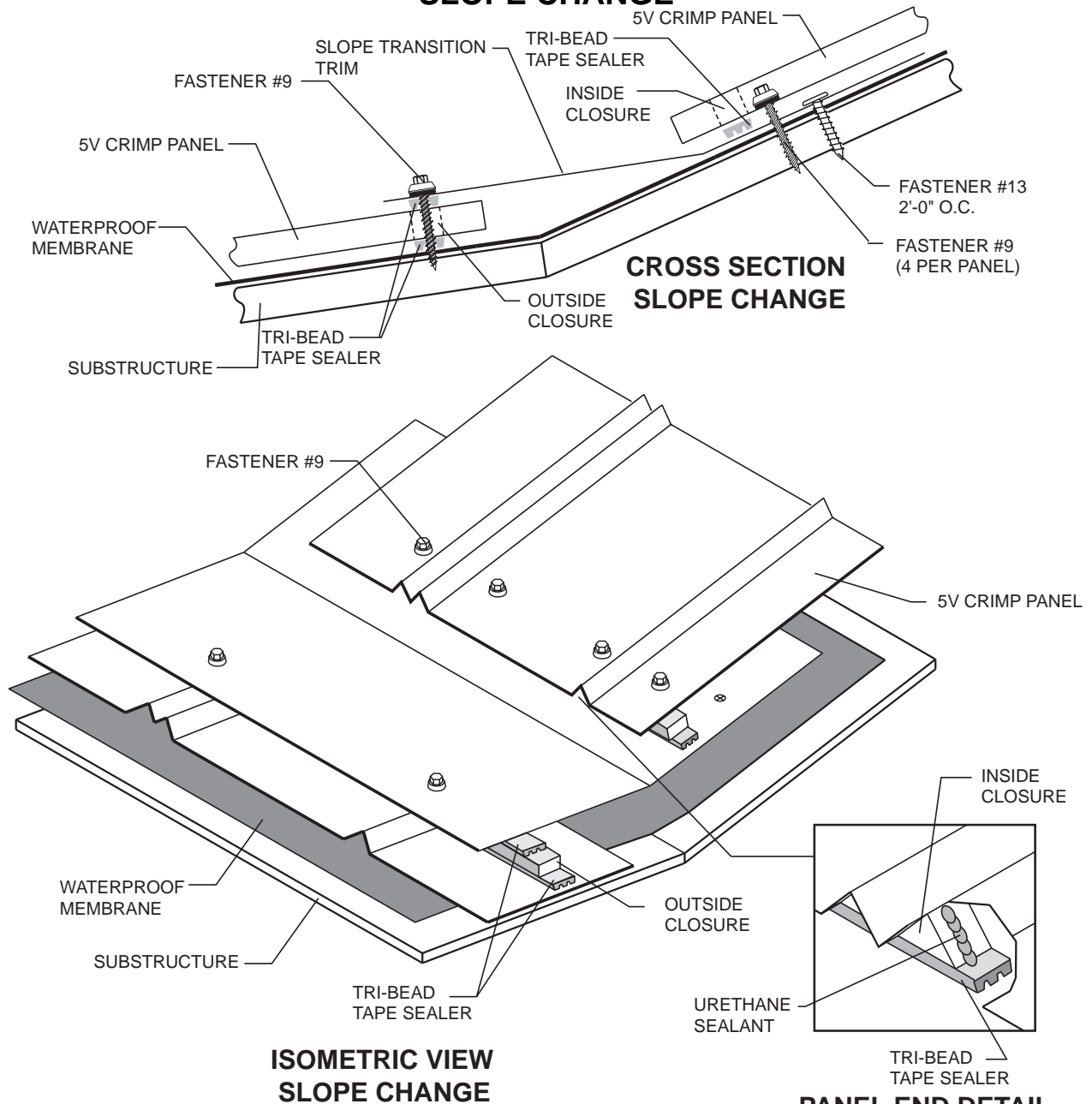

NOTES:

1. Install eave panel with Fastener #9 (10 x 1½" Long Life Wood Grip). Apply Tri-Bead tape sealant on the bottom and top of the outside closure that is mounted down hill from the end of panel.
2. Install transition trim on top of the outside closure with hem of the trim being 1 inch from Fastener #9 (10 x 1½" Long Life Wood Grip) that is located 1'-0" O.C. and placed in the high part of the rib.
3. Fasten down top of trim with two Fasteners #13 (10 x 1" pancake head) per 10'-0" section of trim. Place Tri-Bead tape sealant on top of trim prior to placement of inside closure. Closure should be 1" from end of panel. Sealant on top of trim prior to placement of inside closure. Closure should be 1" from end of panel.
4. Apply a large bead of urethane sealant to top of the inside closure prior to placing panel on top of closure.
5. Attach uphill panel with Fastener #9 (10 x 1½" Long Life Wood Grip). Fastener pattern is shown on Page V-7.

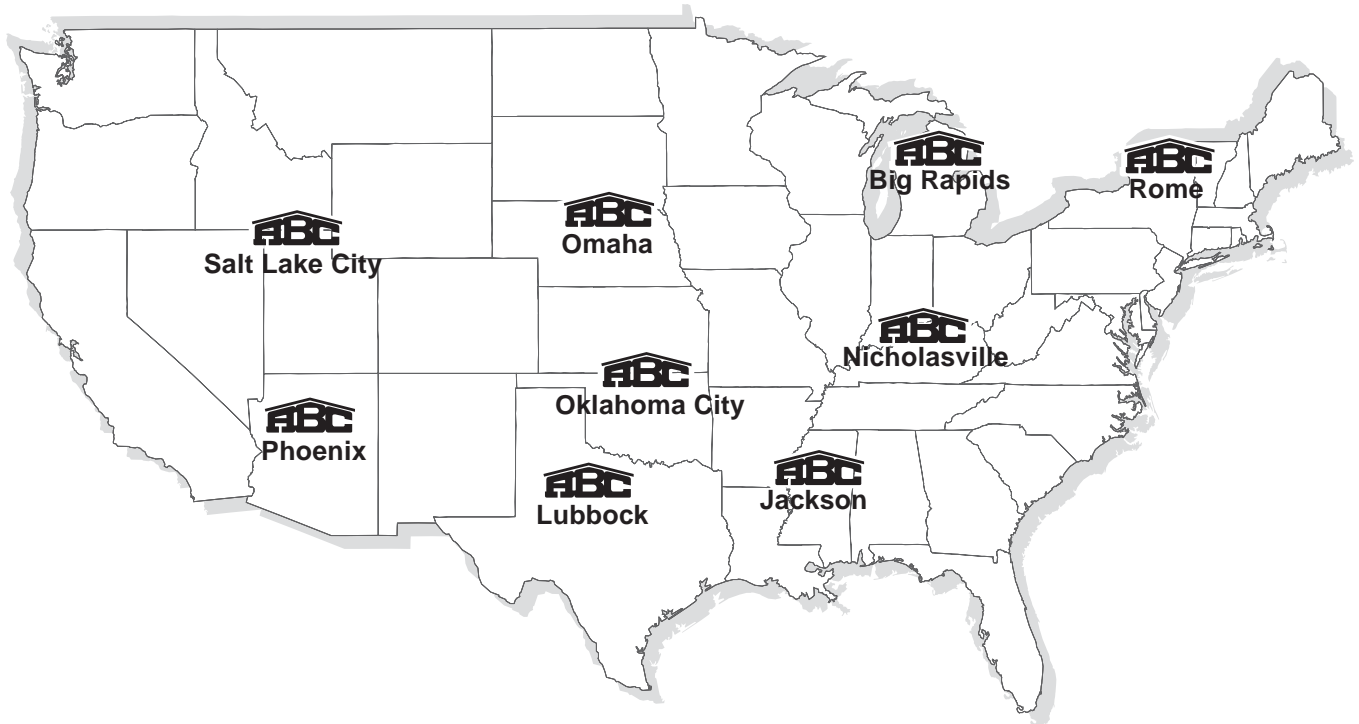

Contact **American Building Components** at
the plant located nearest you for
information on any of our fine products.
For the most current information, see our website at
www.abcmetalroofing.com



Big Rapids, MI
866-334-4222

Jackson, MS
800-622-4136

Lubbock, TX
888-800-5387

Nicholasville, KY
800-877-8709

Oklahoma City, OK
888-800-5387

Omaha, NE
800-228-2260

Phoenix, AZ
800-481-3035

Rome, NY
800-544-2651

Salt Lake City, UT
800-481-3035